

# 492.3.381

## Vacuum cleaner motor performance

# DOMEL®

Vacuum cleaner motors 492.3.381/ 800W/ 36V DC are used for wet and dry aspiration. They are suitable for mobile cleaning machines, powered by battery. Technical data and dimensions are given in the table. Vacuum cleaner motors consist of universal commutator motor and two fan stages. The rotor is supported with two ball bearings enabling vertical or horizontal installation of motor.

The motor is designed for insulation class 130 (B) and constructed according to EN 60335-1.

### Technical data:

|                   |              |        |                                      |
|-------------------|--------------|--------|--------------------------------------|
| Normal operation: | $P_m$        | $\geq$ | 650 W                                |
| Vacuum:           | $P_{max}$    | $\geq$ | 15,9 kPa<br>64,0 in H <sub>2</sub> O |
| Air Flow:         | $Q_{max}$    | $\geq$ | 47 dm <sup>3</sup> /s<br>100 CFM     |
| Air Power:        | $P_{2max}$   | $\geq$ | 264 W                                |
| Efficiency:       | $\eta_{max}$ | $\geq$ | 34 %                                 |
| Mass:             | $m$          | =      | 2,10 kg                              |

|                |         |
|----------------|---------|
| Voltage:       | 36 V DC |
| Frequency:     | -       |
| Nominal Power: | 800 W   |

## Max power 800W

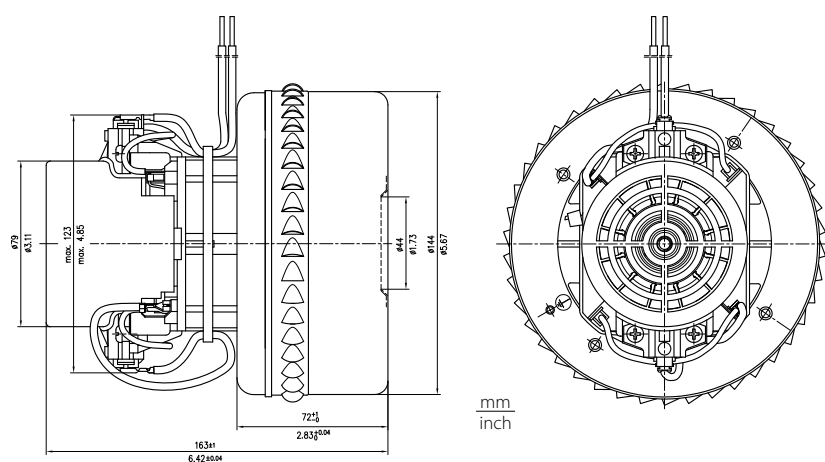

Dimensional and performance data are subject to change without notice.

| Orifice |       | Current | Input Power | Speed             | Pressure |                     | Air Flow           |      | Air power | Efficiency |
|---------|-------|---------|-------------|-------------------|----------|---------------------|--------------------|------|-----------|------------|
| mm      | in*   | A       | W           | min <sup>-1</sup> | kPa      | in H <sub>2</sub> O | dm <sup>3</sup> /s | CFM  | W         | %          |
| 40      | 1 1/2 | 22,18   | 802         | 16545             | 2,2      | 9,0                 | 45,6               | 96,5 | 102       | 12,7       |
| 30      | 1 1/8 | 22,34   | 808         | 16508             | 5,6      | 22,5                | 40,2               | 85,2 | 225       | 27,8       |
| 23      | 7/8   | 21,63   | 782         | 16800             | 9,3      | 37,3                | 30,2               | 64,0 | 281       | 35,9       |
| 19      | 3/4   | 20,58   | 746         | 17304             | 11,1     | 44,4                | 22,4               | 47,5 | 248       | 33,3       |
| 16      | 5/8   | 19,44   | 706         | 17769             | 12,2     | 49,0                | 16,7               | 35,4 | 204       | 28,9       |
| 13      | 1/2   | 18,30   | 664         | 18345             | 13,3     | 53,5                | 11,5               | 24,4 | 154       | 23,1       |
| 10      | 3/8   | 16,86   | 613         | 19028             | 14,3     | 57,4                | 7,1                | 15,0 | 101       | 16,5       |
| 6,5     | 1/4   | 15,72   | 572         | 19818             | 15,2     | 60,9                | 3,1                | 6,6  | 47        | 8,3        |
| 0       | 0     | 14,70   | 533         | 20650             | 16,2     | 65,0                | 0,0                | 0,0  | 0         | 0,0        |

Data above represent the performance of an average motor sample. Individual data may vary due to normal manufacturing variations.

\* Orifice in inch is only approximative.